

IMPORTANT SAFETY INSTRUCTIONS

The apparatus shall not be exposed to dripping or splashing and that no objects filled with liquids, such as vases, shall be placed on the apparatus. The MAINS plug is used as the disconnect device, the disconnect device shall remain readily operable.

Warning: the user shall not place this apparatus in the confined area during the operation so that the mains switch can be easily accessible.

1. Read these instructions before operating this apparatus.
2. Keep these instructions for future reference.
3. Heed all warnings to ensure safe operation.
4. Follow all instructions provided in this document.
5. Do not use this apparatus near water or in locations where condensation may occur.
6. Clean only with dry cloth. Do not use aerosol or liquid cleaners. Unplug this apparatus before cleaning.
7. Do not block any of the ventilation openings. Install in accordance with the manufacturer's instructions.
8. Do not install near any heat sources such as radiators, heat registers, stoves, or other apparatus (including amplifiers) that produce heat.
9. Do not defeat the safety purpose of the polarized or grounding-type plug. A polarized plug has two blades with one wider than the other. A grounding type plug has two blades and a third grounding prong. The wide blade or the third prong is provided for your safety. If the provided plug does not fit into your outlet, consult an electrician for replacement of the obsolete outlet.
10. Protect the power cord from being walked on or pinched particularly at plug, convenience receptacles, and the point where they exit from the apparatus.
11. Only use attachments/accessories specified by the manufacturer.
12. Use only with a cart, stand, tripod, bracket, or table specified by the manufacturer, or sold with the apparatus. When a cart is used, use caution when moving the cart/apparatus combination to avoid injury from tip-over.
13. Unplug this apparatus during lightning storms or when unused for long periods of time.
14. Refer all servicing to qualified service personnel. Servicing is required when the apparatus has been damaged in any way, such as power-supply cord or plug is damaged, liquid has been spilled or objects have fallen into the apparatus, the apparatus has been exposed to rain or moisture, does not operate normally, or has been dropped.

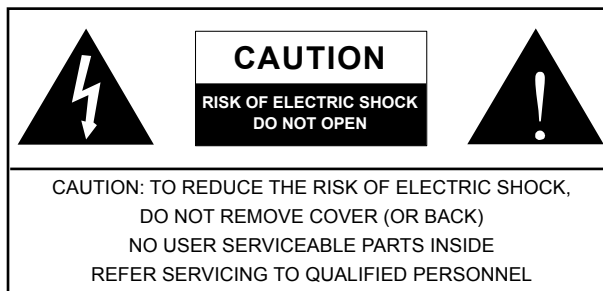

The lightning flash with arrowhead symbol, within an equilateral triangle, is intended to alert the user to the presence of uninsulated "dangerous voltage" within the product's enclosure that may be of sufficient magnitude to constitute a risk of electric shock to persons.



The exclamation point within an equilateral triangle is intended to alert the user to the presence of important operating and maintenance (servicing) instructions in the literature accompanying the appliance.

WARNING: To reduce the risk of fire or electric shock, do not expose this apparatus to rain or moisture.

CAUTION: Use of controls or adjustments or performance of procedures other than those specified may result in hazardous radiation exposure.



T8200

TUBE OPTIMIZER

USER'S MANUAL

TABLE OF CONTENTS

INTRODUCTION	4
FEATURES	4
INITIAL SETUP	4
CONTROLS & CONNECTIONS	5
APPLICATION	8
BLOCK DIAGRAM.....	10
DIMENSIONS.....	12
SPECIFICATIONS.....	13
APPENDIX: Typical Connectors.....	14

INTRODUCTION

PHONIC T8200 TUBE OPTIMIZER is a new generation two-channel audio compressor, featuring dual band controls with variable crossover frequency. Each band has its own independent controls for compression threshold, ratio, and attack time. The VU meters provide instantaneous display of the input/output level and the gain reduction level. A bypass switch in each channel allows quick comparison between the pre- and post-processed signal content. The LINK option allows simultaneous control of both channels.

The dynamic controls on T8200 effectively eliminate the excessive level of the signals from microphones or other sources in a studio recording session or during a live event, making it an indispensable tool for any professional audio engineer.

FEATURES

- Variable tube effect for fine adjustment on sound quality or timbre
- Variable crossover for user-defined frequency bands
- Independent compression controls for low and high bands
- Automatic optimization of compression attack and release
- Relay controlled bypass
- Channel-link function
- Balanced XLR and 1/4" TRS input and output
- VU meters for input, output, and gain reduction
- Operating levels of +4 dBu and -10 dBV independently selectable for input and output

INITIAL SETUP

The following is a recommended initial setup for your T8200 TUBE OPTIMIZER.

For both Channels 1 and 2:

- 1 Make sure the PROCESSOR switch is set to the IN position.
- 2 Set the INPUT LEVEL and OUTPUT LEVEL control knobs to 0 dB.
- 3 Set the TUBE TIMBRE control knob to COLD.

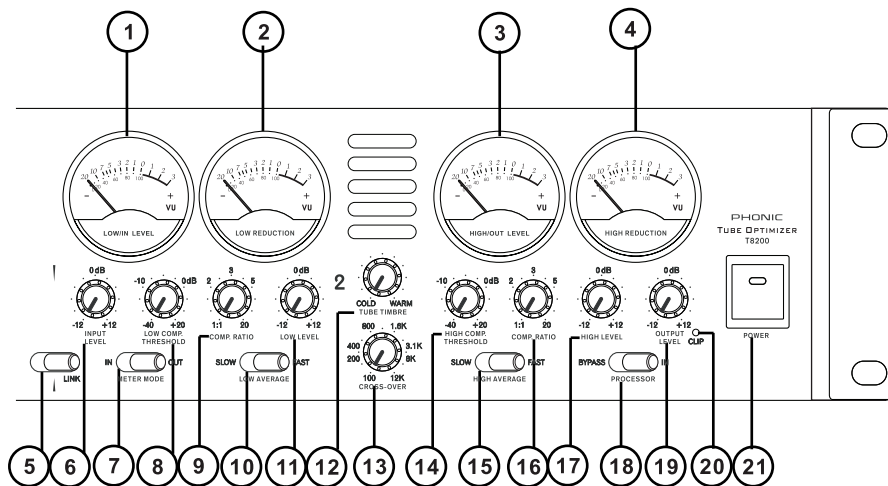

CONTROLS & CONNECTIONS

The T8200 Tube Optimizer has two channels that have identical controls and connections. The following descriptions apply to both channels.

Front Panel

1 LOW/IN LEVEL meter

The METER MODE switch determines what this VU meter measures. When the METER MODE switch is set to IN, this meter measures the level of the channel input. When the METER MODE switch is set to OUT, this meter measures the level of the low band.

2 LOW REDUCTION meter

This VU meter displays low band's gain reduction.

3 HIGH/OUT LEVEL meter

The METER MODE switch determines what this VU meter measures. When the METER MODE switch is set to IN, this meter measures the level of the channel output. When the METER MODE switch is set to OUT, this meter measures the level of the high band.

4 HIGH REDUCTION meter

This VU meter displays high band's gain reduction.

5 Channel-link switch

This switch determines whether Channel 1 and Channel 2 are to be controlled separately (SEP.) or in sync (LINK). When the switch is set to LINK, the settings for Channel 1 are applied to both channels.

6 INPUT LEVEL control

This knob controls the channel's input level. The range of control is from -12 to +12 dB.

7 METER MODE switch

This switch determines what will be measured by the LOW/IN LEVEL and HIGH/OUT LEVEL meters. When this switch is set to IN, the LOW/IN LEVEL and HIGH/OUT LEVEL meters measure the levels of the channel input and output, respectively. When the switch is set to OUT, the LOW/IN LEVEL and HIGH/OUT LEVEL meters measure the levels of the low and high bands, respectively.

8 LOW COMP. THRESHOLD control

This knob controls the threshold level of the low band. Any signal above this level is compressed. The threshold can be set at any level between -40 and +20 dB.

9 (Low) COMP. RATIO control

This knob controls the compression ratio for the low band, ranging from 1:1 to 20:1.

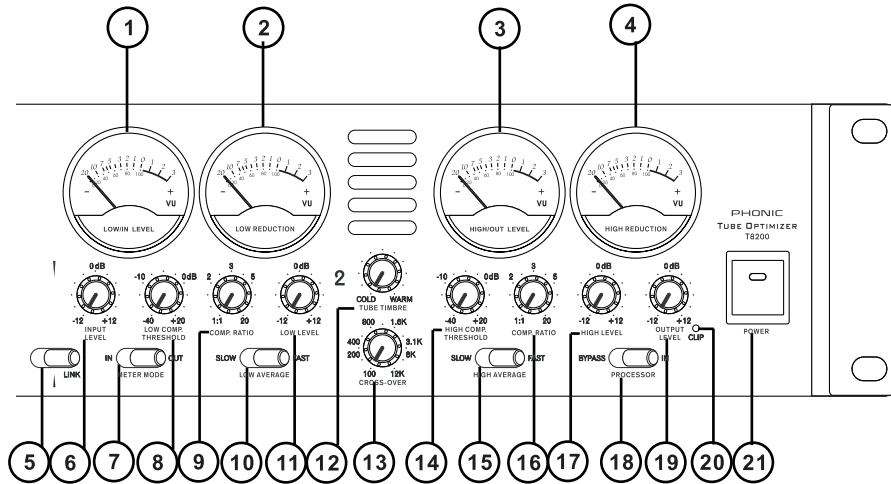

12 TUBE TIMBRE control

Use this knob to control the sound quality or timbre. Turn toward WARM for a richer sound or toward COLD for less.

13 CROSS-OVER control

This knob determines the crossover frequency, the dividing point between low and high bands. The crossover can be set anywhere from 100 Hz to 12 kHz.

14 HIGH COMP. THRESHOLD control

This knob controls the threshold level of the high band. Any signal above this level is compressed. The threshold can be set at any level between -40 and +20 dB.

15 HIGH AVERAGE switch

This switch determines the compressor's average attack time for the high band, SLOW or FAST.

16 (High) COMP. RATIO control

This knob controls the compression ratio for the high band, ranging from 1:1 to 20:1.

17 HIGH LEVEL control

This knob controls high band's level. The range of control is from -12 to +12 dB.

18 PROCESSOR bypass switch

This switch determines whether the signal from the channel input should be processed (IN) or unaltered (BYPASS) before it is sent to the channel output. A bypass switch is useful for a quick comparison between processed and unprocessed sounds.

19 OUTPUT LEVEL control

This knob controls the channel's output level. The range of control is from -12 to +12 dB.

20 CLIP indicator

This LED indicator lights up when clipping occurs. If this indicator lights up frequently, reduce level to avoid distortion.

21 POWER switch

This button switches the unit on (depressed) or off (released).

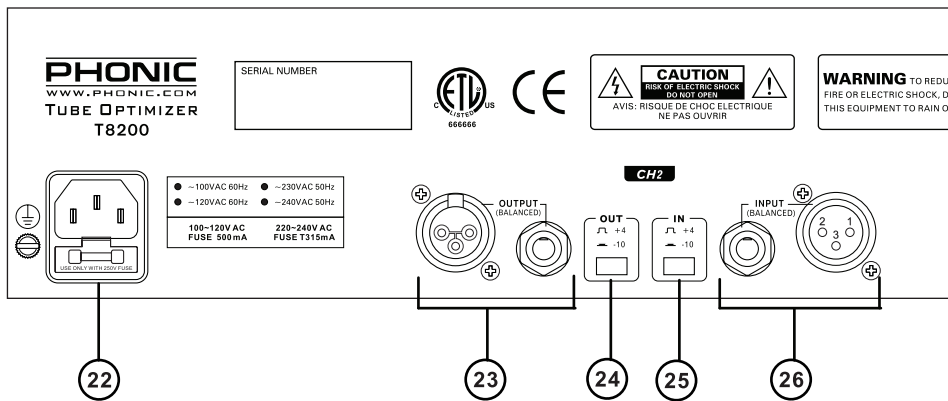

Rear Panel

22 Power inlet and fuse holder

Use the supplied power cord to connect the unit to an AC power outlet of suitable voltage. To change the fuse, slide open the fuse cover with a screwdriver, then replace the fuse with one that is of identical type.

23 OUTPUT connectors

The output connection is equipped with a male XLR and a 1/4" TRS jack. Both connectors are balanced.

24 Output operating level (OUT)

This button determines the operating level of the output signal: -10 dBV when depressed, and +4 dBu when released. This setting should match the operating level of the target device. In general, consumer products use -10 dBV, while professional products use +4 dBu.

25 Input operating level (IN)

This button determines the operating level of the input signal: -10 dBV when depressed, and +4 dBu when released. This setting should match the operating level of the source device. In general, consumer products use -10 dBV, while professional products use +4 dBu.

26 INPUT connectors

The input connection is equipped with a female XLR and a 1/4" TRS jack. Both connectors are balanced.

APPLICATION

With T8200 TUBE OPTIMIZER, you can eliminate excess signals from your mixer, as well as add enhancement to the sounds you create.

BY USING THE INSERT POINT THROUGH AN INSERT CORD

If there is an insert point on your mixer, you may process the signal from that insert point by connecting the T8200 to the insert point via an insert cord. See Appendix for an illustration of some typical connectors.

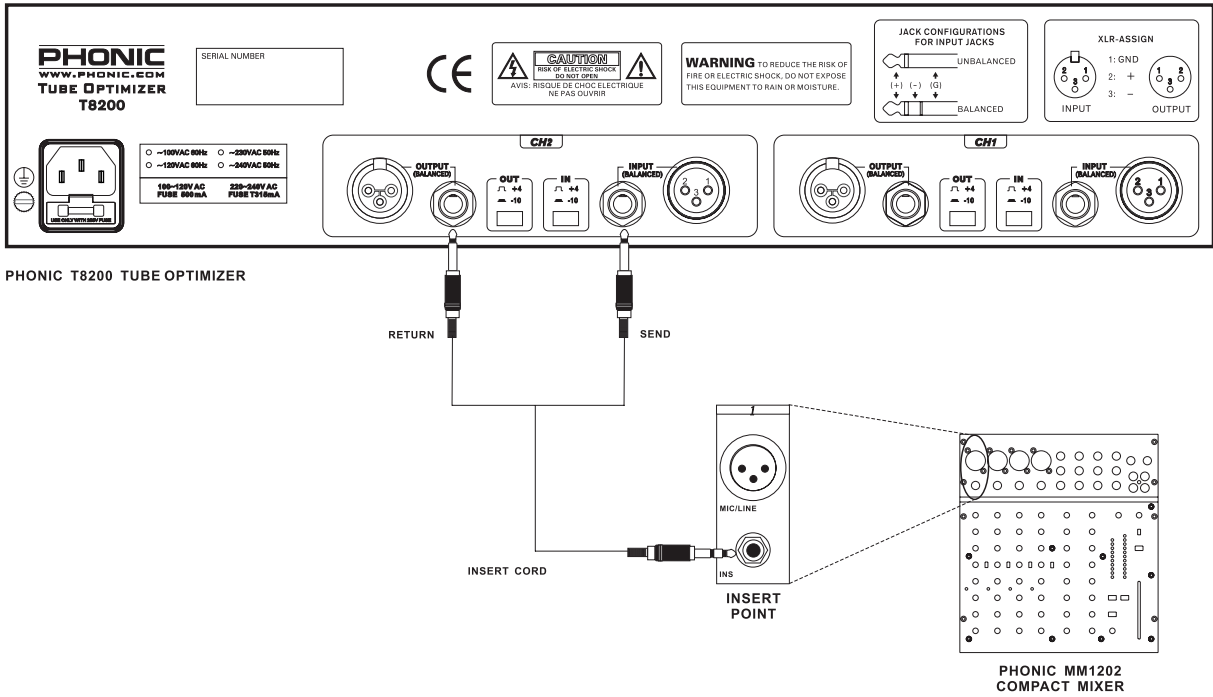

BY USING ANOTHER INPUT CHANNEL

If your mixer does not have any insert point, or if you have used all available insert points, you may use one of the input channels as a return input. Following these steps:

- 1 Connect the AUX (or EFX) output to the input of T8200.
- 2 Connect the output of T8200 to one of the input channels in the mixer.
- 3 To avoid feedback, turn down or mute the AUX-send (or EFX-send) control for the channel receiving input from T8200.
- 4 Through this routing, the original signal is sent from the mixer to T8200 for processing; it is then sent back to the mixer for mixing. Now you should be able to hear T8200's processed signal through the main output.

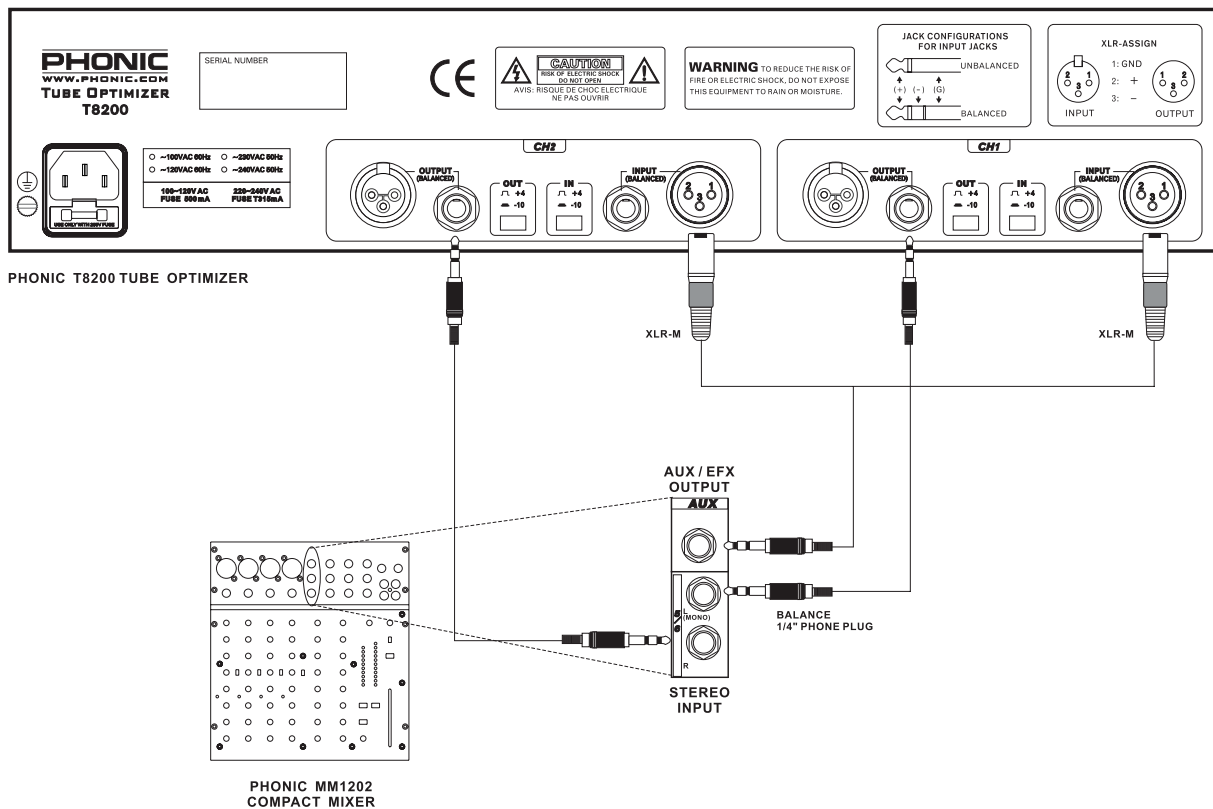

BLOCK DIAGRAM

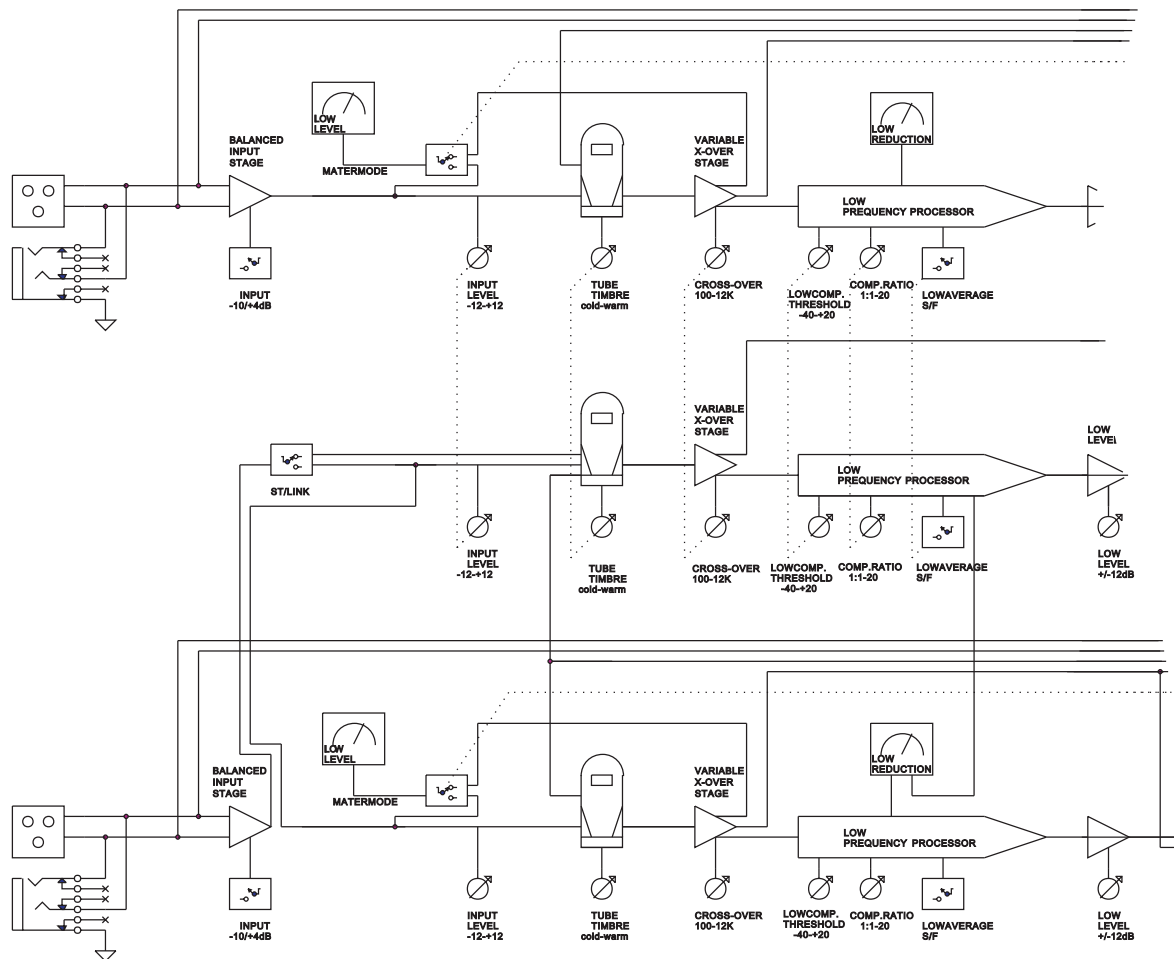

BLOCK DIAGRAM

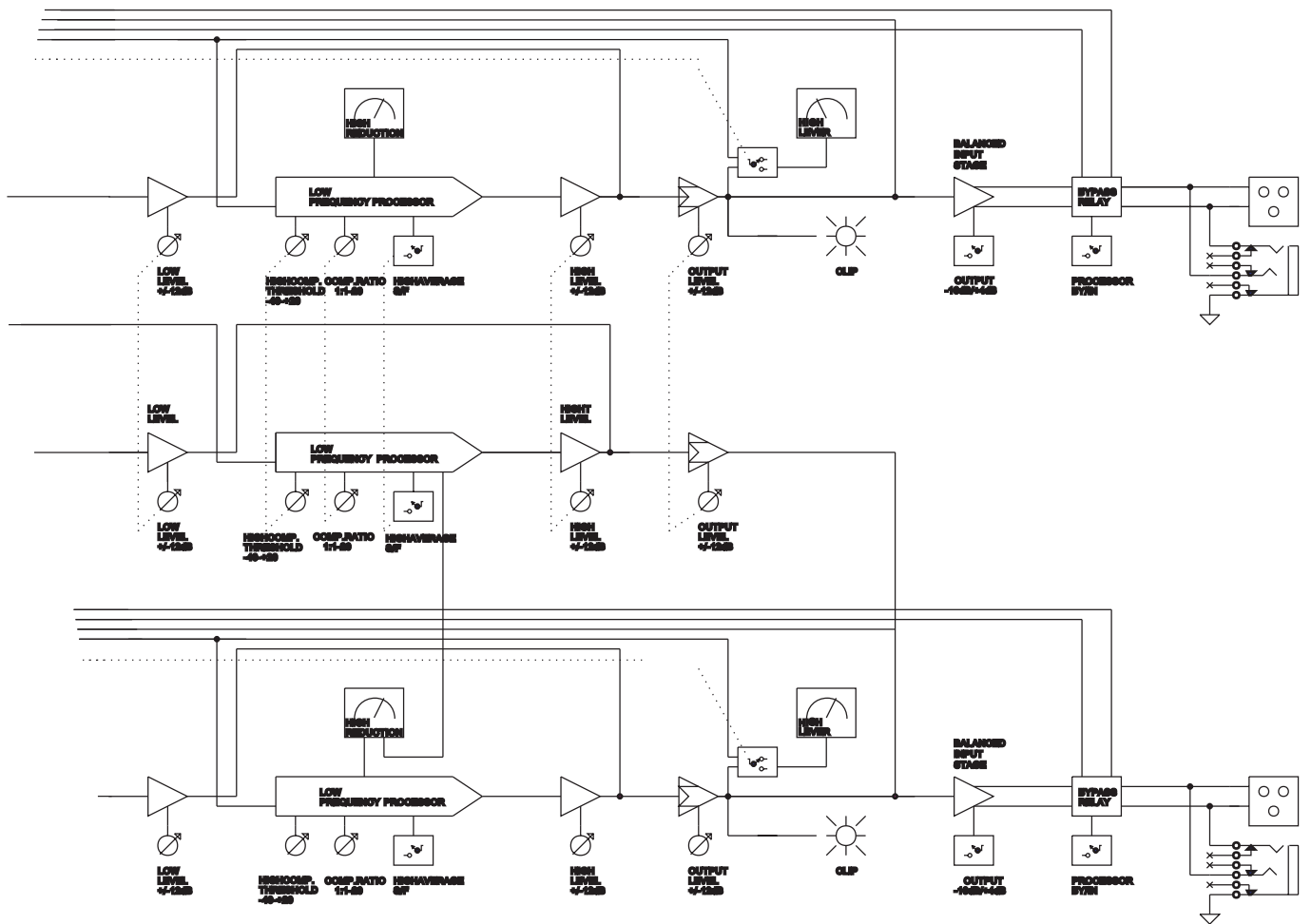

DIMENSIONS

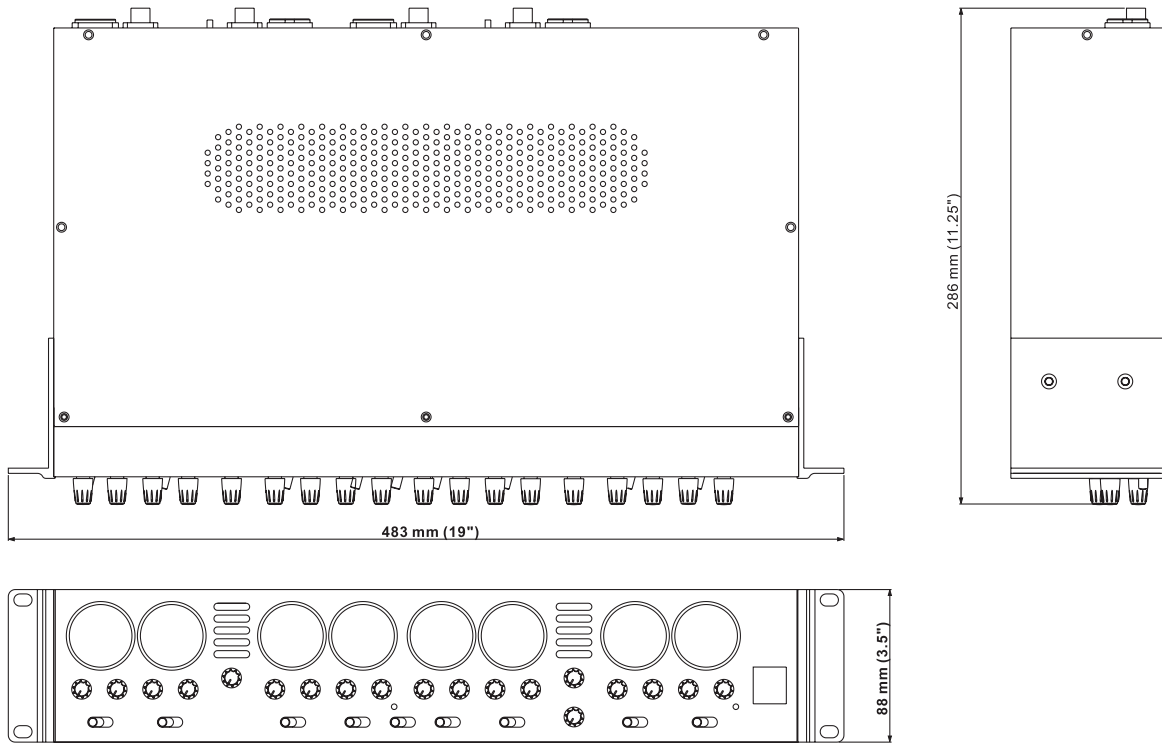

SPECIFICATIONS

Inputs

Connectors	XLR and 1/4" TRS
Type	RF filtered, servo-balanced input
Impedance	50k ohms balanced, 10k ohms unbalanced
Nominal Operating Level	-10 dBV and +4 dBu
Maximum Input Level	+21 dBu
CMRR	60 dB @ 1 kHz

Outputs

Connectors	XLR and 1/4" TRS
Type	Electronically servo-balanced output stage
Impedance	60 ohms balanced, 30 ohms unbalanced
Maximum Output Level	+21 dBu, +20 dBm balanced and unbalanced
Nominal Operating Level	-10 dBV and +4 dBu

System Specifications

Bandwidth	18 Hz to 30 kHz, +/- 2 dB
Noise	> -90 dB
THD	0.1% @ 0 dB, 1 kHz
Crosstalk	< -85 dB, 22 Hz to 22 kHz

Warmth

From 100% direct to 100% tube sound

Meters & Indicators

Per channel: Clip LED
Per band: Input/Output VU Meter, Reduction VU Meter
Per channel: Input Level, Output Level, Tube Timbre, Variable Crossover

Controls

Per band: Threshold Level, Comp. Ratio, Output Level

Switches

Channel Link
Per channel: Meter Mode, Bypass, Input Intensity, Output Intensity
Per band: Attack Time, Output Level

Power Supply

Power Consumption	30 watts maximum
Power Connector	Standard IEC connector
Operating Voltages	100-120V AC 60Hz, 220-240V AC 50Hz
Fuse	100-120V AC: T 1 Ah; 200~240V AC: T 500 mAh

Physical

Dimension (WxHxD)	483 x 88 x 286 mm (19 x 3.5 x 11.25 in.)
Weight	4.9 kg (10.8 lbs.)

TO PURCHASE ADDITIONAL PHONIC GEAR AND ACCESSORIES

To purchase Phonic gear and optional accessories, contact any authorized Phonic distributor. For a list of Phonic distributors please visit our website at www.phonic.com and click on Get Gear. You may also contact Phonic directly and we will assist you in locating a distributor near you.

SERVICE AND REPAIR

Phonic has over 100 service centers worldwide. For replacement parts, service and repairs please contact the Phonic distributor in your country. Phonic does not release service manuals to consumers, and advice users to not attempt any self repairs, as doing so voids all warranties. You can locate a dealer near you at www.phonic.com.

WARRANTY INFORMATION

Phonic stands behind every product we make with a no-hassles warranty. Warranty coverage may be extended, depending on your region. Phonic Corporation warrants this product for a minimum of one year from the original date of purchase against defects in material and workmanship under use as instructed by the user's manual. Phonic, at its option, shall repair or replace the defective unit covered by this warranty. Please retain the dated sales receipt as evidence of the date of purchase. You will need it for any warranty service. No returns or repairs will be accepted without a proper RMA number (return merchandise authorization). In order to keep this warranty in effect, the product must have been handled and used as prescribed in the instructions accompanying this warranty. Any tempering of the product or attempts of self repair voids all warranty. This warranty does not cover any damage due to accident, misuse, abuse, or negligence. This warranty is valid only if the product was purchased new from an authorized Phonic dealer/distributor. For complete warranty policy information, please visit <http://www.phonic.com>.

CUSTOMER SERVICE AND TECHNICAL SUPPORT

We encourage you to visit our online help at <http://www.phonic.com/help/>. There you can find answers to frequently asked questions, tech tips, driver downloads, returns instruction and other helpful information. We make every effort to answer your questions within one business day.

Phonic America Corporation
6103 Johns Road, #7
Tampa, FL 33634
(813) 890-8872
support@phonic.com
<http://www.phonic.com>

PHONIC

PHONIC
WWW.PHONIC.COM